

TOSHIBA

Toshiba DOCSIS Cable Modem

Owner's Manual

PCX1000/PCX1100



Jan. 2000

Copyright 2000, Toshiba Corporation. All rights reserved. This manual may not be reproduced, in part or in whole, without the permission of Toshiba Corporation. The content of this manual is subject to change without notice in the future. Toshiba Corporation assumes no liability for damages resulting from the use of this product or the information contained in this manual.

Table of Contents

Congratulations on Your Purchase	2
Contact Information	2
Support Information	2
Sales Information	2
Web Page	2
Important Rules for Safe Operation	3
Installation	3
Use	4
Service	5
Overview	6
How does a cable modem work?	6
How does a cable modem connect to a computer?	6
What is DOCSIS?	7
Getting Started	8
What's in the box?	8
Front Panel LEDs	8
Connectors and Switches	8
Diagnostics	9
Specifications	10
How to Use the Stand	11
Q & A	12
FCC Compliance	13
Glossary	14
Installing the Cable Modem	Back Cover

TOSHIBA

Congratulations on Your Purchase!

Your new Toshiba DOCSIS Cable Modem will provide you with high-speed access to the Internet through your cable TV (CATV) network- accesses at a fraction of the time it takes traditional telephone modems. In addition, your service will be always connected. Those two features give you the information you want, when you want it ... and your telephone line is kept free.

Contact information

Support Information

Phone: (949) 583-3223

Fax: (949) 583-3597

e-mail: cablesupport@networks.toshiba.com

Sales Information

Phone: (949) 461-4840

e-mail: cablesales@networks.toshiba.com

Web Page

<http://networks.toshiba.com>



Important Rules for Safe Operation

In addition to the careful attention devoted to quality standards in the manufacture of your Toshiba DOCSIS Cable Modem, safety is a major factor in the design of every product. However, safety is your responsibility, too.

This section lists important information that will help assure your enjoyment and proper use of the Cable Modem and accessory equipment. Please read them carefully before operating and using your modem.

Installation

Read and Follow Instructions - You should read all the safety and operating instructions before operating the modem. Follow all operating instructions.

Retain Instructions - You should save all the safety and operating instructions, for your future reference.

Heed Warnings - Comply with all warnings on the products and in the operating instructions.

Check Power Sources - Operate this product only from the type of power source indicated on the product's marking label. If you are not sure of the type of power supplied to your home, consult your dealer or local power company.

Be Careful of Overloading - Do not overload wall outlets or extension cords, as this can result in a risk of fire or electric shock. Overloaded AC outlets, extension cords, frayed power cords, damaged or cracked wire insulation, and broken plugs are dangerous. They may result in a shock or fire hazard. Periodically examine the cord, and, if its appearance indicates damage or deteriorated insulation, have it replaced by your service technician.

Protect Power Cords - Route power supply cords so that they are not likely to be walked on or pinched by items placed upon or against them.

Pay particular attention to cords where they are attached to plugs and convenience receptacles, and examine the point where they exit from the product.

Check Ventilation - Slots and openings in the enclosure are provided for ventilation to ensure reliable operation of the product and to protect it from overheating. Do not block or cover these openings. Never block these openings by placing the product on a bed, sofa, rug, or other similar surface. Never place this product near or over a radiator or heat register, or any other heat source (including amplifiers). Do not place this product in a built-in installation, such as a bookcase or equipment rack, unless you provide proper ventilation.

Do Not Use Accessories - Do not use attachments, unless they are recommended by Toshiba, as they may cause electrical or fire hazards.

Use the Recommended AC Adaptor - You must use the Adaptor that comes with your Toshiba Cable Modem.

TOSHIBA

Do Not Use Near Water - Do not use this product near water - for example, near a bath tub, wash bowl, kitchen sink or laundry tub, in a wet basement or near a swimming pool, and the like.

Do Not Place Near High Temperature Source - for example near a steamer, Kitchen range fire, and the like.

Use Caution in Mounting This Product - Do not place this product on an unstable surface or support. The product may fall, causing serious injury to a child or adult, as well as serious damage to the product.

Use Care in Moving Product-and-Cart Combinations - Quick stops, excessive, force and uneven surfaces may cause the product-and-cart combination to overturn.

Ground the Cable System - Be sure that the outside cable system is grounded, so as to provide some protection against voltage surges and built-up static charges.

Section 810 of the National Electric Code, ANSI/NFPA No. 70-1984 (Section 54 of the Canadian Electrical Code, Part 1) provides information with respect to proper grounding of the cable system.

Do not disconnect RF cable from your Cable Modem while the power to your modem is on.

USE

Unplug Power Before Cleaning - Do not use liquid cleaner or aerosol cleaner. Use a damp cloth for cleaning.

Keep Objects Out of Openings - Never push objects of any kind into this product through openings, as they may touch dangerous voltage or "short-out" parts, which could result in a fire or electric shock. Never spill liquid on the product.

Protect From Lightning - For added protection for this product during a lightning storm, or when it is left unattended and unused for long periods of time, unplug it from the wall outlet, and disconnect the cable system. This will prevent damage to the product due to lightning and power line surges.

Take at least 10 seconds between DC plug off and on.

Service

Do Not Remove Covers - Do not attempt to service this product yourself, as opening or removing covers may expose you to dangerous voltage or other hazards. Refer all servicing to qualified service personnel.

Unplug this product from the wall outlet carefully, as the AC adaptor may be hot. Refer Servicing to Qualified Service Personnel Under the Conditions Listed Below

- ◆ When the power supply cord or plug is damaged.
- ◆ If liquid has been spilled or objects have fallen into the product.
- ◆ If the product has been exposed to rain or water.
- ◆ If the product does not operate normally by following the operating instructions.
- ◆ If the product has been dropped or the cabinet has been damaged.
- ◆ When the product exhibits a distinct change in performance, such as the inability to perform basic functions - this indicates a need for service.

Require Safety Check - Upon completion of any service or repairs to this product, ask the service technician to perform safety checks recommended by service point to determine that the product is in safe operating condition.

TOSHIBA

Overview

The modem provides you with high-speed data communications over the television cable network by following the widely accepted DOCSIS/MCNS standards being developed by the Multimedia Cable Network System (MCNS) consortium. Those standards offer a combination of high performance and interoperability among many of the cable system operators in North America.

How does a cable modem work?

As you know, digital signals are represented by high and low electrical voltage levels. And how fast these levels can switch and still be transmitted is determined by the "bandwidth" of the transmission system. The pair of wires used in a telephone connection have greatly limited bandwidth, because of their electrical characteristics. So what we do is connect a device called a modem between the computer output and the phone line. The modem generates an electrical wave whose strength and phase change in step with the highs and lows of the computer's digital output. It's because of the "smoothness" of the resultant signal that a higher data rate can be transmitted.

A cable modem MODulates and DEModulates electrical signals in the same sense that the telephone modem does. However, since coaxial cable can carry much higher wave frequencies, cable modems are far more sophisticated. Their internals can include a tuner, a bridge, a router, an encryption/decryption device, an SNMP agent and an Ethernet hub. Furthermore, none of the activity caused by these circuits and codes disturbs your regular cable TV reception.

How does a cable modem connect to a computer?

The 10BASE-T Ethernet connection used in this Cable Modem is emerging as the most popular. This connection has been used for years to allow business computers to talk to each other in a LAN (Local Area Network).

The new DOCSIS standard may change this in the future. But for now, an Ethernet card must be installed in your computer for the Cable Modem to work.

What is DOCSIS?

Data Over Cable Service Interface Specifications. DOCSIS defines interface requirements for cable modems involved in high-speed data distribution over a cable television network. On November 17, 1997, Cable Television Laboratories, Inc. (Cable Labs) and its members established a formal path of certification for cable modem equipment suppliers to obtain an interoperability seal for their products based on the DOCSIS specification. This certification process provides cable modem equipment suppliers with a fast, market-oriented method for attaining cable industry acknowledgment of compliance with DOCSIS.

The seal is meant to provide the purchaser with a way to be confident that the modem equipment to be purchased is compliant with the specification, and that the equipment interoperates with DOCSIS products made by other vendors.

Getting Started

What's in the Box?

Make sure that you've received the following items. If any item is missing or damaged, contact your dealer immediately.

- ◆ Toshiba DOCSIS Cable Modem
- ◆ Ethernet Cable (6feet)
- ◆ AC Adaptor (AD-121AN)
- ◆ Stand
- ◆ This manual

Front Panel LEDs

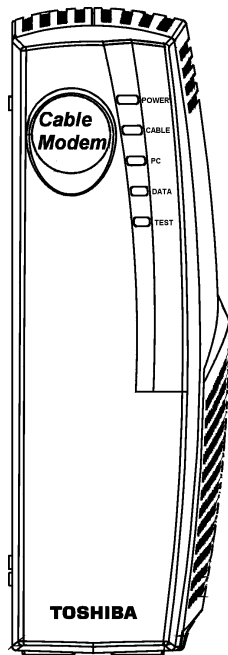

Connectors and Switches

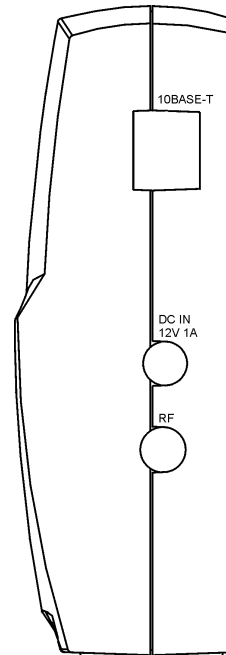

Refer to the back cover for cable modem installation instructions.

Diagnostics

The Cable Modem has five status LEDs for diagnostics. You can monitor the LEDs during installation and when you are using.

Table 1 shows Cable Modem status LEDs and identifies what each LED light means. This table will help you to diagnose problems.

Function	Color	Definition
Power	Green	<ul style="list-style-type: none"> - dark for power off - solid for power on
Cable	Green	<ul style="list-style-type: none"> - dark for no downstream RF carrier present or power off - flashing slowly for downstream RF carrier present and ranging in progress - flashing fast for registration in progress - solid for the Cable Modem registered and ready to transfer data
PC	Green	<ul style="list-style-type: none"> - dark for no Ethernet carrier present or power off - solid for Ethernet carrier present
Data	Green	<ul style="list-style-type: none"> - dark for no user data going through the Cable Modem or power off - flashing for user data going through the Cable Modem
Test	Amber	<ul style="list-style-type: none"> - dark for initial self-test of the Cable Modem OK or power off - flashing for initial self-test of the Cable Modem in progress or software down loading of the Cable Modem in progress - solid for self-test failure of the Cable Modem

Table 1 Status LEDs

How to Use the Stand

Please attach the stand to the bottom of the cable modem

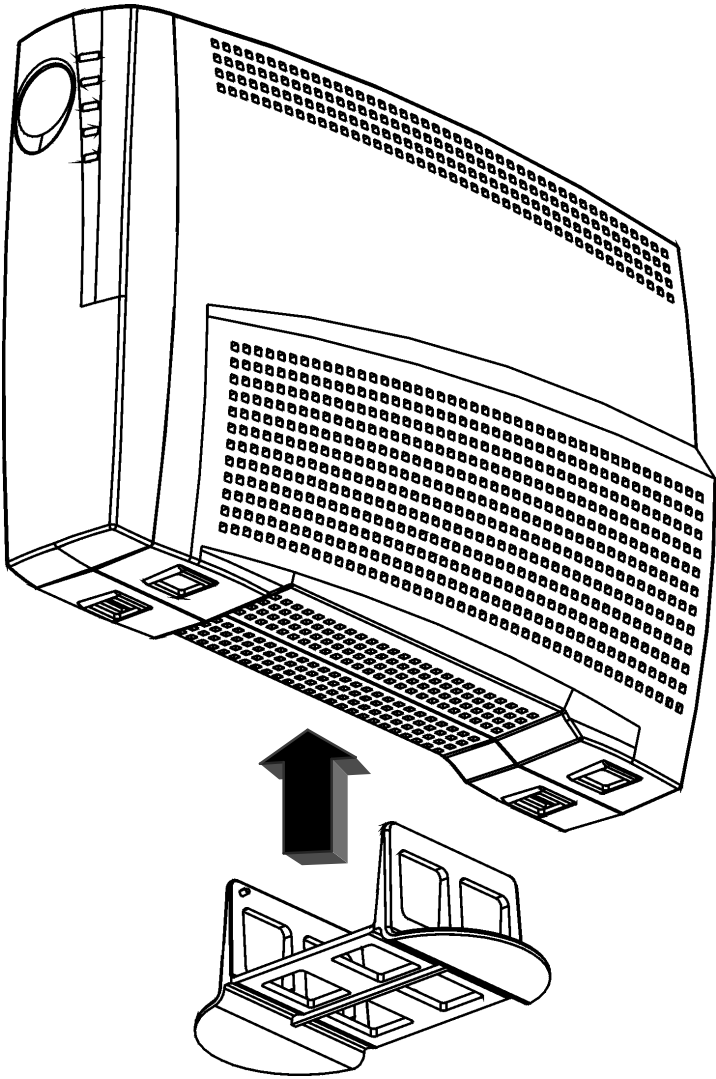

Specifications

The Toshiba DOCSIS Cable Modem is DOCSIS/MCNS compliant.

Receiver

Physical Speed:	30 Mbps (64QAM) / 43 Mbps (256QAM)
Symbol rate:	5.056941 Msym/sec (64QAM); 5.360537 Msym/sec (256QAM)
Demodulation:	64QAM / 256QAM
Bandwidth:	6 MHz
Frequency range:	88 MHz to 860 MHz (edge-to-edge) in 62.5 kHz steps
Input signal level:	-15dBmV to +15dBmV
Input impedance:	75 ohms
Return loss:	> 6 dB from 88 MHz to 860 MHz

Transmitter

Physical Speed:	320,640,1280,2560,5120Kbps(QPSK) 640,1280,2560,5120,10240Kbps(16QAM)
Symbol rate:	160, 320, 640, 1280, 2560 ksym/sec
Modulation:	QPSK / 16QAM
Bandwidth:	200, 400, 800, 1600, 3200 kHz
Frequency range:	5 to 42 MHz (edge-to-edge), in 1Hz steps
Output signal level:	8 dBmV to 58 dBmV (QPSK) 8 dBmV to 55 dBmV (16QAM)

PC Interface

10BASE-T:	10Mbps; half-duplex
-----------	---------------------

Power

AC adapter input:	120VAC @ 60Hz
AC adapter output to cable modem:	12VDC @1A
AC Power consumption:	8 W (Typ)

Mechanical

Size:	1.96 in. (width) x 8.07 in. (depth) x 5.96 in. (height)
Weight:	2.1 lb

Environmental

Operating temperature:	32 to 104 degrees Fahrenheit
Humidity:	10 to 90 percent (non-condensing)
Storage temperature:	-4 to 140 degrees Fahrenheit
Safety:	UL1310, UL1950
Emission:	FCC part 15, class B
Accessory:	AC Adapter

Q & A

Q: How to connect the cable modem to the hub/switch ?

A: Cable Modem is connected to the uplink port on the hub/switch. Or use cross-over Ethernet cable to connect the normal port on the hub/switch. Please make sure that hub/switch supports 10BASE-T. Cable modem supports only 10BASE-T.

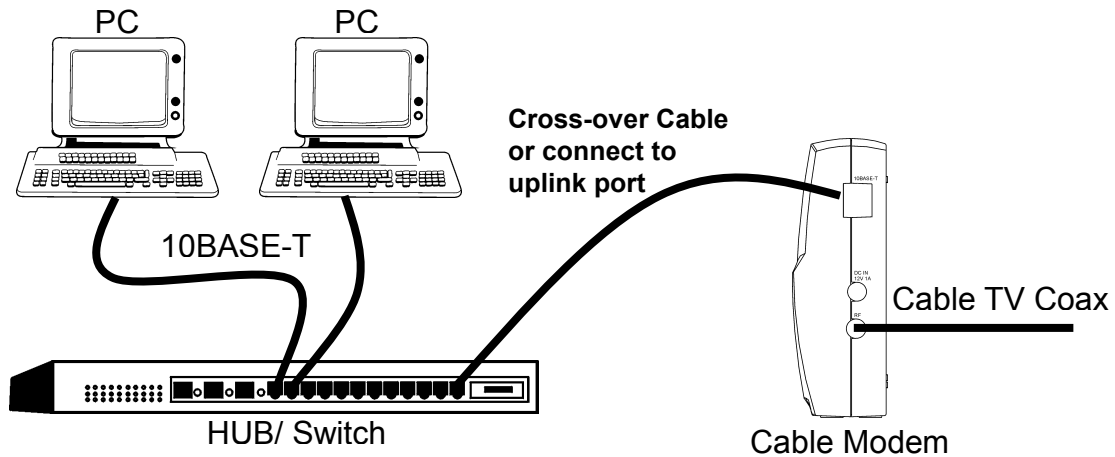

Q: Do I need to turn off the cable modem ?

A: You can leave cable modem on all the time.

Q: How can I connect multiple PC to the cable modem?

A: You can use hub or switch for physical connection. Cable modem is controlled by Cable Operator to allow how many PCs is available. Please contact local Cable Operator to activate multiple PC under the cable modem.

Q: Where can I download the driver for Cable modem?

A: The cable modem is a stand-alone device that have an Ethernet Port. All workstations or hub must have a 10 Base T Ethernet port or card to connect to the cable modem. Since the cable modem is a stand alone device, there is no special driver needed on the workstation.

Q: How can I configure the modem and get monitoring information from the modem?

A: The modem can only be configured and monitored by your cable operator.

FCC Compliance

This Toshiba DOCSIS Cable Modem has been tested and found to comply with the limits for a Class B personal computer and peripherals, pursuant to Part 15 of the FCC Rules. These limits are designed to provide reasonable protection against harmful interference in a residential installation. This equipment generates, uses and can radiate radio frequency energy and, if not installed and used in accordance with the instructions, may cause harmful interference to radio communications. However, there is no guarantee that interference will not occur in a particular installation. If this unit does cause harmful interference to radio or television reception, which can be determined by turning the unit off and on, the user is encouraged to try to correct the interference by one or more of the following measures:

- ◆ Reorient or relocate the receiving antenna.
- ◆ Increase the separation between the equipment and receiver.
- ◆ Connect the equipment into an outlet on a circuit different from that to which the receiver is connected.
- ◆ Consult the dealer or experienced radio/TV technician for help.

Glossary

10BASE-T

Unshielded, twisted pair cable with an RJ-45 connector, used with Ethernet LAN. “10” indicates the speed (10 Mbps), “Base” refers to baseband technology, and “T” means twisted pair cable.

Cable TV Coax

Cable that allows wide bandwidth transmission over long distances. Coaxial cable (coax) comprises an inner conductor surrounded by insulation. An outer conductor wraps around the insulation, which, in turn, is covered by an outer plastic covering.

Ethernet card

A plug-in circuit board installed in an expansion slot of a personal computer. The Ethernet card (sometimes called a Network Interface Card, or NIC) takes parallel data from the computer, converts it to serial data, puts it into a packet format, and sends it over the 10BASE-T LAN cable.

F connector

A type of coaxial connector, labeled RF on the rear of the Toshiba Cable Modem, that connects the modem to the cable system.

Headend

The equipment, in the central office of the service provider, where the cable signals originate.

Hybrid Fiber/ Coaxial (HFC) system

A system where the trunk of the cable plant is of fiber technology. Somewhere near the subscriber’s home, the fiber is connected to a coaxial cable, and the signal is converted so that it’s compatible with the fiber media. The coaxial cable then runs through the branches of the network and is finally dropped into the home.

HUB

A device used to connect multiple computers to the cable modem.

Internet

A collection of interconnected networks used for worldwide computer-based communications.

IP Address

A unique, 32-bit address assigned to every device in a network. An IP (Internet Protocol) address has two parts: 1) a network address and 2) a host address. Each network is assigned an address by a government agency, and each company administrator assigns an address to each host computer.

Modem registration

The process the Toshiba Cable Modem uses to make itself known to the headend equipment. Once authorized by the router, the modem is assigned upstream and downstream channels for data communication.

Network driver

A (software) file included with the Ethernet card. The file is loaded on the computer to allow the computer to recognize the Ethernet card. See Ethernet Card.

RJ-45

Connector on the Toshiba Cable Modem, labeled 10BASE-T, that connects the modem to a computer or to a HUB.

Subscriber

A computer user in the home who accesses a data service using the Toshiba Cable Modem.

Subnet

A network subdivision. When subnetting is used, the IP (Internet Protocol) address is divided into a subnet number and a host number. Hosts and gateways identify the bits used for the network and subnet number through the use of a subnet mask.

TCP/IP communication stack

Software in the subscriber computer that processes packets through the communication layers. The subscriber configures the IP address for the computer and the router default gateway in the software. The TCP/IP communication stack handles all the communications with the subscriber's application.

Installing the Cable Modem

To avoid thermal problems, allow at least one inch spacing between the ventilation holes and any object to either side of the unit. It's best to have no obstructions on top of the unit. The top of the unit should be at least two inches from any obstruction.

Connect the cable modem using the following steps, referring to the figure below.

1. Connect the Cable TV coax to the input connector of a signal splitter.
2. Connect a coaxial cable from one of the output connectors of the splitter to the input connector of the television set.
3. Connect a coaxial cable from the other output connector of the splitter to the RF input connector on the cable modem rear panel.
4. Connect the 10Base-T signal cable from your computer to the 10Base-T connector on the cable modem rear panel.
5. Connect the AC adaptor to the DC IN 12V 1A jack on the cable modem rear panel. Then plug in the AC adaptor to the wall electrical outlet.

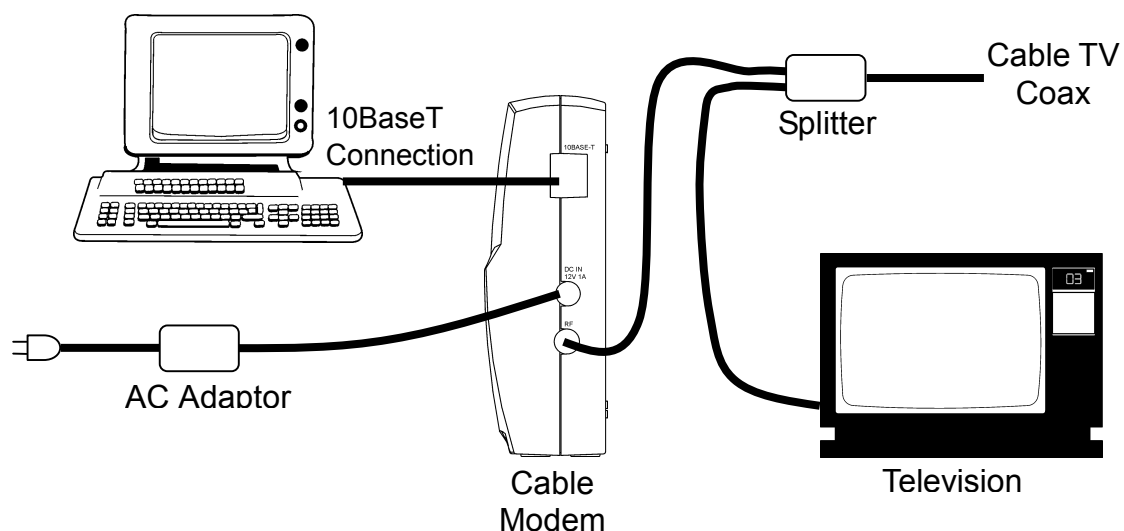

The power indicator LED on the modem front panel will light, if power is present at the outlet. The modem will start operating once power is connected. No additional operator intervention is required. It will automatically find the data channel, register and connect to your computer.

Check the cable modem status. The front panel indicators (LEDs) show that the cable modem is operating properly when they are in the following condition:

- POWER – lit
- CABLE - lit
- PC - lit
- DATA - flashing or not lit
- TEST - not lit